

# Wheel loader RT100/100D

For Earth, For Life  
Kubota



Standard Equipment	RT100	RT100D
Tyres 23 x 8.50-12 Skid	✓	✓
Transmission hydrostatic 4 wheel drive with automotive control	✓	✓
Driving system: 4 hydraulic wheel motors	✓	✓
Differential lock: electric controlled	✓	✓
Electric shuttle on joystick	✓	✓
Front attachment controlled by joystick	✓	✓
Auxiliary circuit 1 at front end-double acting - mechanically activated	✓	✓
Floating position	✓	✓
ROPS / FOPS canopy	✓	✓
Deluxe seat with safety belt, armrest and extended backrest	✓	✓
Lifting hooks	✓	✓
2 Working lights on arm	✓	✓
1 Working light at rear		✓
Parallel Indicator on tilt cylinder		✓
Main switch	✓	✓
Free return hydraulic oil		✓
Towing hook		✓
Cyclone filter	✓	✓
Oil Cooler	✓	✓
Traffic homologation kit (traffic lights and mirrors)	✓	✓
Parking brake: hydraulic multidisc brake	✓	✓
Mechanical quick-hitch compact	✓	
Hydraulic quick-hitch compact		✓

# Specifications

For Earth, For Life



<b>Model name</b>			<b>RT100/D</b>
Engine	Make	Kubota	
	Model	D722	
	Displacement	CC	719
	Output	HP(kW)	20(15)
Service weight		kg	1100
Tipping load		kg	1000
Driving speed		km/h	0~15
Lifting capacity	A	kg	1000
	B	kg	800
	C	kg	550
Auxiliary circuit	Oil flow	LT/Min	28
	Oil pressure	Bar	180



# Dimensions

<b>Model name</b>			<b>RT100/D</b>
A	Wheel base	mm	1205
B	Overall length w/o bucket	mm	2200
C	Overall height with canopy	mm	2060
D	Overall width	mm	960
E	Height front frame	mm	1380
F	Max. dumping height	mm	1408
G	Max. bucket pin height	mm	2170
H	Height with bucket	mm	2976

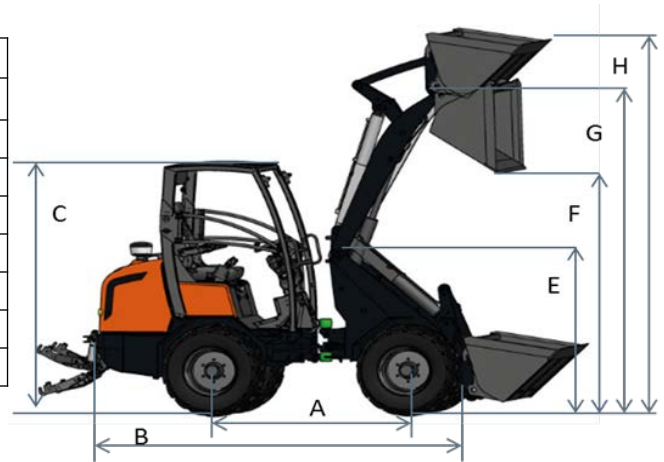

# Basic accessories

Earth bucket



Pallet fork



**Kubota Europe S.a.s.**  
 19-25 rue Jules Verceyusse  
 BP 50088- Z.I.  
 95101 Argenteuil Cedex  
 France  
 Tel: +33(0)1 34 26 34 34  
 Fax : +33(0) 1 34 26 34 21  
[www.kubota.fr](http://www.kubota.fr)