

Wheel Loader RT 270/270D

For Earth, For Life
Kubota



Standard Equipment	RT270	RT270D
Tyres 31 x 15.5-15 Skid		✓
Tyres 31 x 15.5-15 TR-06	✓	
Transmission: hydrostatic 4 wheel drive with automotive control	✓	✓
Driving system : heavy planetary end drive	✓	✓
Differential lock: 100% electric differential lock on both axles	✓	✓
Electric shuttle on joystick	✓	✓
Front attachment controlled by joystick	✓	✓
Auxiliary circuit 1 at front end - double acting - mechanically activated	✓	✓
Floating position	✓	✓
ROPS / FOPS canopy deluxe version (safety doors-4 working lights)	✓	
ROPS / FOPS cabin including air heater - 4 working lights		✓
Radio and speakers		✓
Deluxe seat with safety belt, armrest and extended backrest	✓	✓
Auxiliary circuit 2 at front end - double acting - electric activated		✓
Main switch	✓	✓
Second speed	✓	✓
Free return hydraulic oil		✓
Towing hook	✓	✓
Working light on arm	✓	✓
Cyclone filter	✓	✓
Mudguard wideners		✓
Oil cooler	✓	✓
Traffic homologation kit (traffic lights and mirrors)	✓	✓
Parking brake: drum brakes	✓	✓
Hydraulic quick-hitch standard	✓	✓

Specifications

Model name		RT270/D	
Engine	Make	Kubota	
	Model	V1505-T	
	Displacement	CC	1498
	Output	HP(kW)	45(33)
Service weight		kg	2770
Tipping load		kg	2200
Driving speed	1°st speed	km/h	0~10
	2°nd speed	km/h	0~28
Lifting capacity	A	kg	2600
	B	kg	1620
	C	kg	1200
Auxiliary circuit	Oil flow	LT/Min	51
	Oil pressure	Bar	190



A



B C

Dimensions

Model name		RT270/D	
A	Wheel base	mm	1643
B	Overall length w/o bucket	mm	3247
C	Overall height with canopy	mm	2322
C'	Overall height with cabin	mm	2345
D	Overall width	mm	1320
E	Height front frame	mm	1731
F	Max. dumping height	mm	2144
G	Max bucket pin height	mm	2964
H	Height with bucket	mm	3532

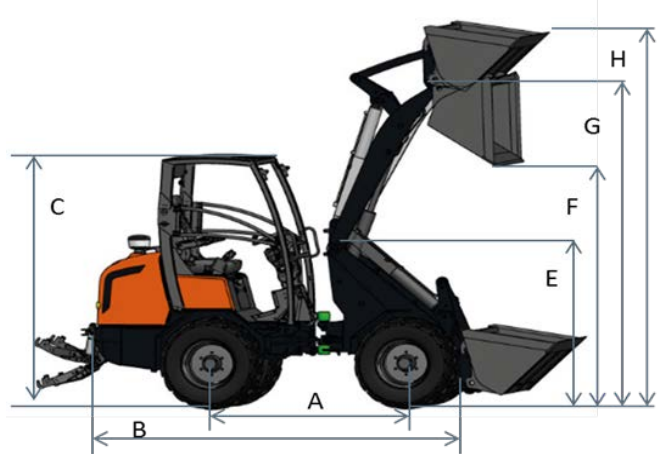

Basic accessories

Earth bucket



Bucket 4 in 1



Pallet fork



Kubota Europe S.a.s.
 19-25 rue Jules Verceyusse
 BP 50088- Z.I.
 95101 Argenteuil Cedex
 France
 Tel: +33(0)1 34 26 34 34
 Fax : +33(0) 1 34 26 34 21
www.kubota.fr